

VIRNIG

Two Cylinder Pipe Pallet Fork Grapple Specifications

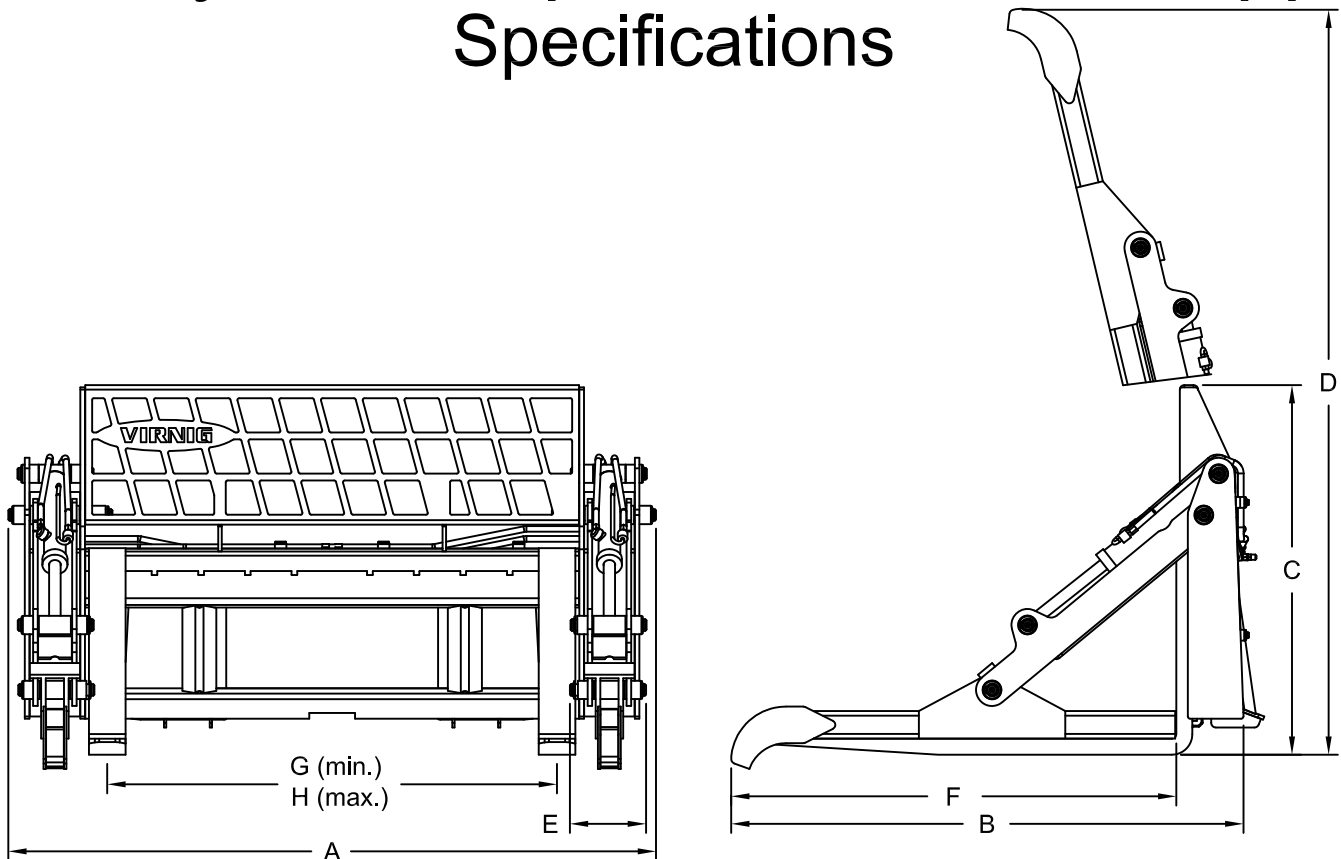

MODEL	PPFG248
A) Overall Width (Inches)	70.8
B) Overall Depth (Inches)	56.0
C) Overall Height, Closed (Inches)	40.4
D) Overall Height, Open (Inches)	81.4
E) Grapple Arm Width (Inches)	8.3
F) Grapple Arm Depth, Closed (Inches)	48.6
G) Minimum Tine Space (Inches)	8.9
H) Maximum Tine Space (Inches)	49.1
Approximate Weight (Pounds)	950

- Recommended for loaders with operating capacities greater than 1500 pounds.
- 1 3/4" X 4" X 48" long forged solid tines.
- 6200 pound capacity, with load center 24" from frame.
- 2 cylinder independent grapple with 1 1/4" diameter hinge pins.
- 2" bore, 8 3/8" stroke cylinder with 1 1/4" rod and 1 1/4" cylinder pins.
- Hoses from grapple to loader and couplers are included.

Specifications and designs are subject to change without notice.

Virnig Manufacturing Inc.
800-648-2408
www.virnigmg.com